

2015-2016 SPREADERS



SALTDogg[®]
by Buyers



SaltDogg[®]
by Buyers

DANGER
Always use proper
operating procedure.

1400465SSE

Our History



1946

 Buyers Products Company founded by Sam Ruven and Bessie Kleinman as a distributor of driveline components.



Buyers continued to grow its product offerings and build valued relationships with customers and suppliers. Increased demand for products led to the pursuit of supply chain manufacturing solutions.

1988

 Buyers acquired Viking Forge in Streetsboro, Ohio with 6 complete forge lines. This facility manufactures our hitches, D-rings, and other towing and cargo parts.



1992
 Buyers acquired Trailer Components Manufacturing (Tracom) for CNC precision machining and tooling, as well as state-of-the-art welding.

1995
 Buyers acquired Progressive Powder Coating, Inc. Our Nordson automatic powder application booth is used to powder coat our Buyers toolboxes and other truck and trailer accessories.



2002
 Buyers moved its corporate headquarters to a brand new 235,000 sq. ft. state-of-the-art office and distribution center.



2004
 Buyers acquired Romotech in New Paris, Indiana. Our Ferry Industries Rotospeed molding machines are used to manufacture our poly salt spreaders.



2007
 Buyers began manufacturing the SnowDogg stainless steel snowplow at our Mentor, Ohio facility.



2009
 Buyers began our operations at Boomerang Rubber, in Botkins, Ohio manufacturing mudflaps, wheel chocks and other rubber truck and trailer accessories.



2013
 Buyers acquired an additional 500,000 sq.ft. manufacturing facility in Mentor, Ohio allowing for expansion of our aluminum and stainless steel manufacturing.



Our Corporate Family of Companies



Founded in 1946, Buyers Products is a fully integrated manufacturer and supplier of products for the mobile equipment industry. **Multiple manufacturing capabilities include forging, stamping, laser cutting, CNC machining, robotic welding, rotational molding, powder coating and assembly.**



Product lines include towing products, toolboxes, truck and trailer hardware, rubber and polymer products, dump body hardware, cables and control systems, hydraulics, pneumatics, driveline components, lights, mudflaps, snowplows, salt spreaders and snow & ice control products.



TAILGATE	Page 4-9
ELECTRIC DRIVE	Page 10-19
GAS DRIVE	Page 20
MID-SIZE GAS/ELECTRIC/HYDRAULIC DRIVE (CONVEYOR)	Page 21
MUNICIPAL GAS OR HYDRAULIC DRIVE (CONVEYOR)	Page 22
MUNICIPAL HYDRAULIC DRIVE (AUGER)	Page 23
MUNICIPAL HYDRAULIC DRIVE (CONVEYOR)	Page 24-25
LIQUID SPRAY SYSTEMS	Page 26-27
UNDER TAILGATE	Page 28-29
REPLACEMENT TAILGATE	Page 30
WALK BEHINDS	Page 31
ACCESSORIES	Page 32
SPECIFICATION CHART	Page 33-35

With a Footprint This Big, We Cover as Much Ground as Winter Does

When you need equipment that you can always depend on... equipment that is guaranteed to be reliable and flexible enough to handle any job, in any situation, no matter what winter might throw at you, you can count on Buyers.

In our 65-plus years, we've grown to be one of the largest manufacturers for mobile equipment and snow removal markets. Our vertically integrated manufacturing facilities ensure the highest quality standards from raw materials to finished products. Make Buyers your single source for spreaders, plows, and pushers.

TGSUV1B Residential Use

SUV, 1/2-ton, 3/4-ton & 1-ton trucks

Spread Material: bagged #1 rock salt

Feed Mechanism: manual open/close gate w/gravity feed

Power Source: electric

- Capacity: 4.4 cu. ft.
- Poly hopper, powder-coated steel frame
- Material spread up to 14'
- 1/8 HP, 12 VDC motor with auxiliary plug adapter
- Mounting hardware for 1-1/4" and 2" receiver hitches
- See additional specs on page 33



3001152 - Auxiliary Plug Adapter
with on-off switch for TGSUV1B

TGSUVPROA Light Commercial Use

SUV, 1/2-ton, 3/4-ton & 1-ton trucks

Spread Material: bagged #1 rock salt

Feed Mechanism: gravity feed w/vertical 12 VDC auger assist

Power Source: electric

- Capacity: 4.4 cu. ft.
- Poly hopper, powder-coated steel frame
- Material spread up to 30'
- 1/2 HP, 12 VDC motor with variable speed controller
- Mounting hardware for 2" receiver hitches
- Prewired for optional vibrator kit (3008241)
- See additional specs on page 33



3011864 - Variable
Speed Controller



TGSUVPROA



TGS02

patented

SUV, 1/2-ton, 3/4-ton & 1-ton trucks

Spread Material: ice melt, bagged salt

Feed Mechanism: horizontal auger feed

Power Source: electric

- Capacity: 3 cu. ft.
- Poly hopper, powder-coated steel frame
- Material spread up to 30'
- 1/3 HP, 12 VDC dual shaft gear motor
- Mounting hardware for 2" receiver hitches
- Prewired for optional vibrator kit (3028195)
- See additional specs on page 33



TGS02



3011864 - Variable Speed Controller

TGS01B

1/2-ton, 3/4-ton & 1-ton trucks

Spread Material: bagged #1 rock salt

Feed Mechanism: gravity feed w/vertical 12 VDC auger assist

Power Source: electric

- Capacity: 8 cu. ft.
- Poly hopper, powder-coated steel frame
- Material spread up to 30'
- 12 VDC motor
- Prewired for optional vibrator kit (3008241)
- Mount directly to step bumper (standard)
- See additional specs on page 33

Options:

- Mount using optional receiver mount for a 2" receiver tube (0207005)
- Mount using the optional Wintergate Spreader Mount, allowing full bed access (025000A)
- Optional auger for finer material (3016232)

TGS05B

1/2-ton, 3/4-ton & 1-ton trucks

Spread Material: bagged #1 rock salt

Feed Mechanism: gravity feed w/vertical 12 VDC auger assist

Power Source: electric

- Capacity: 10.79 cu. ft.
- Low-profile poly hopper, powder-coated steel frame
- Material spread up to 30'
- 12 VDC motor
- Prewired for optional vibrator kit (3008241)
- Mount directly to step bumper (standard)
- See additional specs on page 33

Options:

- Mount using optional receiver mount for a 2" receiver tube (0207005)
- Mount using the optional Wintergate Spreader Mount, allowing full bed access (025000A)
- Optional auger for finer material (3016231)



3011864 - Variable
Speed Controller





TGS06

1/2-ton, 3/4-ton & 1-ton trucks

Spread Material: bagged #1 rock salt

Feed Mechanism: manual open/close gate with gravity feed

Power Source: electric

- Capacity: 10 cu. ft.
- Poly hopper, powder-coated steel frame
- Material spread up to 30'
- 12 VDC motor housed in a sealed chamber
- Mounts to any 2" hitch receiver (includes universal stake pocket attachment)
- Includes 80 lb. vibrator installed
- See additional specs on page 33



TGS06



3011864 - Variable Speed Controller

TGS03

patented

1/2-ton and 3/4-ton trucks

Spread Material: bulk salt, salt & sand mix

Feed Mechanism: horizontal auger feed mechanism with stainless steel trough

Power Source: electric

- Capacity: 8 cu. ft.
- Poly hopper, powder-coated steel frame
- Material spread up to 30'
- 1/2 HP, 12 VDC dual shaft gear motor
- Requires optional vibrator for salt/sand mix (3020340)
- Mounts on 2" Class 4 receiver with horizontal and vertical adjustments to rest on step bumper
- See additional specs on page 33



Available with Red or Yellow Hopper



TGS03 Horizontal Auger with Stainless Steel Trough



Prewired for Optional Vibrator Kit Shown Installed (3020340)



TGS03



3011864 - Variable Speed Controller





TGS07

patented

3/4-ton and 1-ton trucks

Spread Material: bulk salt, salt & sand mix

Feed Mechanism: horizontal auger feed mechanism with stainless steel trough

Power Source: electric

- Capacity: 11 cu. ft.
- Poly hopper, powder-coated steel frame
- Material spread up to 30'
- 1/2 HP, 12 VDC dual shaft gear motor
- Includes 200 lb. concealed vibrator
- Dual action lid
- Mounts on 2" Class 4 receiver with horizontal and vertical adjustments to rest on step bumper
- See additional specs on page 33



Standard Vibrator Kit Shown



TGS07 Horizontal Auger with Stainless Steel Trough



Available with Red or Yellow Hopper



TGS07



3011864 - Variable Speed Controller

www.saltdogg.com

SHPE0750 Series

patented

1/2-ton, 3/4-ton Trucks & Utility Vehicles

Spread Material: bulk salt, salt & sand mix

Feed Mechanism: 2-1/2" stainless steel auger and trough

Power Source: electric

- Capacity: 0.75 cu. yds.
- Double-wall poly-molded hopper
- Material spread up to 30'
- Two 12 VDC direct drive gear motors (1/2 HP for auger, 1/4 HP for spinner)
- 2-1/2" diameter stainless steel auger and trough
- Spinner assembly can be easily removed for cleaning and storage
- Includes 200 lb. vibrator, top screen, tarp, tie-downs, remote auger bearing grease kit
- See additional specs on page 33



SHPE0750
on Utility Vehicles



NEW high flow chute with larger 14" spinner, open trough, and shield that better protects truck from flying salt

**2-YEAR
WARRANTY**
on all SHPE
Spreaders



SHPE0750



3014199 - Variable
Speed Controller





SHPE1000 Series

patented

1/4-ton, 1/2-ton, 3/4-ton Trucks

Spread Material: bulk salt, salt & sand mix

Feed Mechanism: 2-1/2" stainless steel auger and trough

Power Source: electric

- Capacity: 1.00 cu. yds
- Double-wall poly-molded hopper
- Material spread up to 30'
- Two 12 VDC direct drive gear motors (1/2 HP for auger, 1/4 HP for spinner)
- 2-1/2" diameter stainless steel auger and trough
- Spinner assembly can be easily removed for cleaning and storage
- Includes 200 lb. vibrator, top screen, tarp, tie-downs, remote auger bearing grease kit
- See additional specs on page 33

ELECTRIC DRIVE



NEW high flow chute with larger 14" spinner, open trough, and shield that better protects truck from flying salt



2-YEAR WARRANTY
on all SHPE Spreaders



SHPE1000



3014199 - Variable Speed Controller

SHPE1500 Series

patented

3/4-ton and 1-ton Trucks

Spread Material: bulk salt, salt & sand mix

Feed Mechanism: 2-1/2" stainless steel auger and trough

Power Source: electric

- Capacity: 1.5 cu. yds.
- Double-wall poly-molded hopper
- Material spread up to 30'
- Two 12 VDC direct drive gear motors (1/2 HP for auger, 1/4 HP for spinner)
- 2-1/2" diameter stainless steel auger and trough
- Spinner assembly can be easily removed for cleaning and storage
- Includes 200 lb. vibrator, top screen, tarp, tie-downs, remote auger bearing grease kit
- See additional specs on page 33

Not recommended for highway use



Available with
Red or Yellow
Hopper



NEW high flow chute with larger 14" spinner, open trough, and shield that better protects truck from flying salt



3014199 - Variable
Speed Controller





SHPE2000 Series

patent pending

3/4-ton and 1-ton Trucks

Spread Material: bulk salt, salt & sand mix

Feed Mechanism: 2-1/2" stainless steel auger and trough

Power Source: electric

- Capacity: 2.00 cu. yds
- Double-wall poly-molded hopper
- Material spread up to 30'
- Two 12 VDC direct drive gear motors (1/2 HP for auger, 1/4 HP for spinner)
- 2-1/2" diameter stainless steel auger and trough
- Spinner assembly can be easily removed for cleaning and storage
- Includes 200 lb. vibrator, top screen, tarp, tie-downs, remote auger bearing grease kit
- See additional specs on page 33

Not recommended for highway use

ELECTRIC DRIVE



NEW high flow chute with larger 14" spinner, open trough, and shield that better protects truck from flying salt



Available with Red or Yellow Hopper



2-YEAR WARRANTY
on all SHPE Spreaders

SHPE2000



3014199 - Variable Speed Controller



SHPE2250 Series

patent pending

1-ton trucks above 10,000 lbs. GVW

Spread Material: bulk salt, salt & sand mix

Feed Mechanism: 5-1/4" carbon steel variable pitch auger, stainless steel trough

Power Source: electric

- Capacity: 2.20 cu. yds. (8')
- Poly-molded hopper
- Material spread up to 30'
- Two 12 VDC direct drive motors (3/4 HP for auger, 1/2 HP for spinner)
- 5-1/4" FULL LENGTH variable pitch auger and stainless steel trough
- Spinner assembly can be easily removed for cleaning and storage
- Chute adjusts 12"
- Includes Top screen, stainless steel inverted V, vinyl tarp with tie-down kit, 12 VDC 200 lb. vibrator
- Optional Remote Grease Kit (3022215) available
- See additional specs on page 33

Not recommended for highway use



Available with
Red or Yellow
Hopper

**2-YEAR
WARRANTY**
on all SHPE
Spreaders

5-1/4"
DIAMETER
FULL LENGTH
VARIABLE
PITCH AUGER

Adjustable
Height
Chute

SHPE2250



3016934 - Heavy Duty
Variable Speed Controller





1400701SS

3/4-ton and 1-ton trucks.

Spread Material: bulk salt, salt & sand mix

Feed Mechanism: 12" wide all steel pintle chain conveyor

Power Source: electric

- Capacity: 1.5 cu. yds. (6')
- 304 stainless steel hopper
- Material spread up to 30'
- Two 12 VDC direct drive motors (3/4 HP for auger, 1/2 HP for spinner)
- Conveyor: 12" wide all-steel pintle chain
- Feedgate: Lever operated with friction lock for accurate adjustment
- Chute Assembly: Six-fin 14" polymer disc, Chute adjusts 11.5"
- Includes top screen, stainless steel inverted V, hold-down kit
- See additional specs on page 33

1400601SS

3/4-ton and 1-ton trucks.

Spread Material: bulk salt, salt & sand mix

Feed Mechanism: 12" wide all steel pintle chain conveyor

Power Source: electric

- Capacity: 2.0 cu. yds. (8')
- 304 stainless steel hopper
- Material spread up to 30'
- Two 12 VDC direct drive motors (3/4 HP for auger, 1/2 HP for spinner)
- Conveyor: 12" wide all-steel pintle chain
- Feedgate: Lever operated with friction lock for accurate adjustment
- Chute Assembly: Six-fin 14" polymer disc, Chute adjusts 11.5"
- Includes top screen, stainless steel inverted V, hold-down kit
- See additional specs on page 33

ELECTRIC DRIVE



304SS

Adjustable
Height
Chute

1400601SS



3016934 - Heavy Duty Variable Speed Controller

SHPE3000

patent pending

13,000 lbs. GVW and above

Spread Material: bulk salt, salt & sand mix

Feed Mechanism: 6" carbon steel auger, stainless steel trough

Power Source: electric

- Capacity: 3 cu. yds. (8' 6")
- Double-wall poly-molded hopper
- Material spread up to 30'
- Two 12 VDC direct drive motors (3/4 HP for auger, 1/2 HP for spinner)
- 6" diameter carbon steel auger and stainless steel trough
- Spinner assembly can be easily removed for cleaning and storage
- Chute adjusts 12"
- Double Doors: Interlocking gutter system and double-door lid channels water away
- Includes top screen, stainless steel inverted V, spreader tie-down kit, hinged poly lids, 12 VDC 400 lb. vibrator
- See additional specs on page 33

Not recommended for highway use

**2-YEAR
WARRANTY**
on all SHPE
Spreader

Auger
Drive

Adjustable
Height
Chute

SHPE3000



3016934 - Heavy Duty
Variable Speed Controller





SHPE3000CH

patent pending

13,000 lbs. GVW and above

Spread Material: bulk salt, salt & sand mix

Feed Mechanism: 12" wide all steel pintle chain conveyor

Power Source: electric

- Capacity: 3 cu. yds. (8' 6").
- Double-wall poly-molded hopper
- Material spread up to 30'
- Two 12 VDC direct drive motors (3/4 HP for auger, 1/2 HP for spinner)
- 12" wide all steel pintle chain conveyor
- Spinner assembly can be easily removed for cleaning and storage
- Chute adjusts 12"
- Double Doors: Interlocking gutter system and double-door lid channels water away
- Includes top screen, stainless steel inverted V, spreader tie-down kit, hinged poly lids
- See additional specs on page 33



2-YEAR WARRANTY
on all SHPE Spreaders

Chain Conveyor

Adjustable Height Chute

SHPE3000CH



3016934 - Heavy Duty Variable Speed Controller

SHPE4000

Minimum GVW of 17,500 lbs.

Spread Material: bulk salt, salt & sand mix

Feed Mechanism: 5-1/2" carbon steel auger, stainless steel trough

Power Source: electric

- Capacity: 4.0 cu. yds. (8' 4")
- Poly-molded hopper with stainless steel frame
- Material spread up to 30'
- Two 12 VDC direct drive motors (3/4 HP for auger, 1/2 HP for spinner)
- 5-1/2" carbon steel auger, stainless steel trough
- Spinner assembly can be easily removed for cleaning and storage
- Includes two top screens, stainless steel inverted V, vinyl tarp with tie-down kit, (2) 12 VDC 400 lb. vibrators
- See additional specs on page 33

Not recommended for highway use

**2-YEAR
WARRANTY**
on all SHPE
Spreaders



304SS
FRAME &
TROUGH

SHPE4000



3014199 - Variable
Speed Controller





SHPE6000

Minimum GVW of 25,999 lbs.

Spread Material: bulk salt, salt & sand mix

Feed Mechanism: 5-1/2" carbon steel auger, stainless steel trough

Power Source: electric

- Capacity: 6.0 cu. yds. (10' 7")
- Poly-molded hopper with stainless steel frame
- Material spread up to 30'
- Two 12 VDC direct drive motors (3/4 HP for auger, 1/2 HP for spinner).
- 5-1/2" carbon steel auger, stainless steel trough
- Weighs 1,000 lbs. less compared to steel/stainless steel
- Spinner assembly can be easily removed for cleaning and storage
- Includes two top screens, stainless steel inverted V, 12 VDC 900 lb. vibrator
- Optional tarp kit (3021928) available
- See additional specs on page 33

Not recommended for highway use



2-YEAR WARRANTY
on all SHPE Spreaders

304SS
FRAME &
TROUGH

SHPE6000



3016934 - Heavy Duty Variable Speed Controller

V-Box Slide-In

3/4-ton and 1-ton pickup, flatbed or dump truck

Spread Material: bulk salt, bulk sand, salt & sand mix

Feed Mechanism: 12" wide all steel pintle chain conveyor

Power Source: gasoline

- 304 Stainless Steel
- Capacity/Material:
 - 1400200SS/1400250SS*: 1.5 cu. yds. (6') Stainless Steel,
 - 1400050/1400100*: 2 cu. yds. (8') Carbon Steel
 - 1400050SS/1400100SS*: 2 cu. yds. (8') Stainless Steel,
 - 1400400/1400450*: 2 cu. yds. (8') Polymer
 - 1400300SS/1400350SS*: 2.5 cu. yds. (10') Stainless Steel
- Material spread up to to 30'
- 10.5 HP Briggs & Stratton Intek industrial/commercial gasoline engine with battery
- 12 VDC electric clutch has a three position on-off-on in-cab switch
- Conveyor: 12" wide all steel pintle chain. Heavy-duty drive shaft with heavy-duty 1-1/8" sealed bearings. Idler shaft with sprocket has heavy-duty 1" diameter sealed bearings
- Conveyor Gear Case: Gear ratio is 20:1 with 1" input shaft and 1-1/8" output shaft on tapered roller bearings.
- Feedgate: Lever operated with friction lock for accurate adjustment.
- Includes top screens, stainless steel adjustable inverted V
- See additional specs and individual part numbers on page 34

* Indicates extended chute models



3010390
Controller



2.5 – 3.0 Cubic Yard Mid-Size

Minimum GVW of 13,000 lbs.

(see www.saltdogg.com for specs by model number)

Spread Material: bulk salt, bulk sand, salt & sand mix

Feed Mechanism: 14-1/2" wide conveyor chain with 1/4" crossbars

Power Source: gasoline, electric, or hydraulic

- Capacity: 2.5 cu. yds. (8'), 2.75 cu. yds. (9'), 3.0 cu. yds. (10'),)
- 304 stainless steel hopper
- Adjustable Feedgate
- Available with 10-1/2 HP gas engine, 2 independent electric motors, or 2 independent hydraulic motors
- 2 Hinged top screens, 1/4" bars
- Inverted V, installed
- Spinner chute has two adjustable internal baffles
- Bolt-on spinner housing
- 14" Poly spinner disc (electric models), 18" Poly spinner disc (on gas and hydraulic models)
- See additional specs and individual part numbers on page 34

MID-SIZE GAS/ELECTRIC/HYDRAULIC DRIVE



Optional Electric-Hydraulic Proportional Spreader Control Kit w/ Garmin® GPS Ground Speed Antenna (HV1030EPG)



304SS



3016934 Controller for electric powdered spreaders



3010390 Controller



3.5 – 5 Cubic Yard

Minimum GVW of 17,500 lbs.

(see www.saltdogg.com for specs by model number)

Spread Material: bulk salt, bulk sand, salt & sand mix

Feed Mechanism: 14-1/2" wide conveyor chain with 1/4" crossbars

Power Source: gasoline, electric, or hydraulic

- Capacity: 3.5 cu. yds. (8'), 4.0 cu. yds. (9'), 4.5 cu. yds. (10'), 5.0 cu. yds. (10')
- 304 stainless steel hopper
- Adjustable Feedgate
- Available with 10-1/2 HP gas engine, 2 independent electric motors, or 2 independent hydraulic motors
- 4 Hinged top screens, 1/4" bars
- Inverted V, installed
- Spinner chute has two adjustable internal baffles
- Bolt-on spinner housing
- 14" Poly spinner disc (electric models), 18" Poly spinner disc (on gas and hydraulic models)
- See additional specs and individual part number on page 34



Optional LS1 Liquid Spray System
(fits 3 - 4.5 cu. yds.)



Optional Cab Guard
(1497051)



Optional Electric-Hydraulic Proportional Spreader Control Kit w/ Garmin® GPS Ground Speed Antenna (HV1030EPG)

Shown with Optional Light Bar (Part No. 8891144)



3010390 Controller
for gas powered spreaders



7 – 10 Cubic Yard

Minimum GVW 33,000 lbs.

(see www.SaltDogg.com for specs by model number)

Spread Material: bulk salt, salt & sand mix

Feed Mechanism: 7" diameter, variable-pitch hard faced auger

Power Source: hydraulic

- Capacity: 7.0 cu. yds. (10'), 8.0 cu. yds. (11'), 9.0 cu. yds. (12'), 10.0 cu. yds. (14')
- 304 Stainless Steel Hopper
- Material spread up to 45'
- Two independent, direct-drive hydraulic motors
- 7" diameter auger with multi-pitch design
- Adjustable height spinner chute
- 3/8" heavy-duty hinged top screens with 4" peak
- 18" poly spinner disc
- See additional specs and individual part number on page 34

Additional sizes/configurations available. Call for quote.



7" Hard Faced Auger



High Torque Auger Motor



2" Auger Bearing



Optional Rubber Side Deflectors
Part No. 1492144



1471056SSH

6 – 16 Cubic Yard

Minimum GVW Chassis 26,000 lbs., – 66,000 lbs.
(see www.SaltDogg.com for specs by model number)

Spread Material: bulk salt, bulk sand, salt & sand mix

Feed Mechanism: 24" wide conveyor with 3/8" bars

Power Source: hydraulic

- Capacity: 6 cu. yds. (9'); 7, 8, 9 cu. yds. (10');
10, 11, 13 cu. yds. (12'); 12, 13, 14 cu. yds. (14')
- 304 stainless steel hopper
- Material spread up to 40'
- Adjustable feedgate
- 24" wide conveyor with 3/8" bars
- Two independent direct drive hydraulic motors
- Choice of three gear box ratios: 50:1, 25:1 or 6:1
- Hinged top screens, 3/8" bars on 2-1/2" openings
- Inverted V, adjustable
- 2" drive shaft and bearings with 8-tooth sprockets
- 1-1/2" spring loaded idler shaft and bearings with 8-tooth sprockets
- Quick release hinged chute (no tools needed)
- 20" Poly spinner disc
- See additional specs and individual part number on page 35

Additional sizes/configurations available. Call for quote.

Shown with optional
8891167 Lightbar and LS4
Liquid Spray System



1450757SSH



5 – 16 Cubic Yard Municipal Spreader Options and Accessories



3025885 SPREADER STAND SHOWN



3027468 SPREADER STAND SHOWN



8891167 Lightbar Kit



8891168 Lightbar Kit



8891169 Lightbar Kit



3020624 Remote Grease Kit



3020624 Stainless Steel Chain Lubricator Kit



3022060 Stainless Steel Folding Spreader Ladder



Anti-Ice Spray Bars



3026067 Lane Changing Chute



HV1030EPG Electric-Hydraulic Control Kit



SMR30VESS Reservoir

PART NO.	DESCRIPTION
3025885	Spreader Stand, 10ft.-11ft., Black Power Coated
3025886	Spreader Stand, 12ft.-13ft., Black Power Coated
3025887	Spreader Stand, 14ft.-15ft., Black Power Coated
3027468	Spreader Stand, 10ft.-11ft., Galvanized
3027469	Spreader Stand, 12ft.-13ft., Galvanized
3027470	Spreader Stand, 14ft.-15ft., Galvanized
3008560	Dump Body Tailgate Latch
3010548	Tie Down Kit, Chain
3020704	16" Chute Extension, SS for taller mounting heights
3020624	Remote Grease Kit, 3-point
3020625	Chain Lubricator Kit, Stainless Steel
3020626	Crank Up Chute Kit
3026067	Lane Changing Chute, 12V w/ cab controller & gas spring flip-up

PART NO.	DESCRIPTION
—	Anti-Ice Spray Bars (Call for Quote)
HV1030EPG	Elec-Hyd Spreader Control Kit, 40GPM
GPS1	Garmin™ GPS Unit w/ Converter
SMR30VESS	30 Gallon Stainless Steel Reservoir
3022060	Folding Stainless Steel Spreader Ladder, Full Size
8891167	66" LED Light Bar Kit (Includes (4) Red LED Round STT lights, (2) Amber LED Round Strobe lights, (3) Red LED Round Marker lights, Wire Harness, (2) LED Load Equalizers and Lightbar)
8891168	66" LED Light Bar Kit (Includes (2) Red LED Oval STT lights, (2) Clear LED Oval Back-Up lights, (2) Amber LED Oval Strobe lights, (3) Red LED Round Marker lights, Wire Harness, (2) LED Load Equalizers and Lightbar)
8891169	66" LED Light Bar Kit (Includes (4) Red LED Oval STT lights, (2) Amber LED Oval Strobe lights, (3) Red LED Round Marker lights, Wire Harness, (2) LED Load Equalizers and Lightbar)

Liquid Spray Systems

Features

- 12 VDC, 3 GPM/45 PSI electric diaphragm pump
- Hydraulic Drive: 4.5 GPM @ 1,750 RPM (150 PSI) with Proportioning Valve, Bronze pump, bronze gears, stainless steel shaft
- 30-gallon polymer reservoir (48"L x 13"W x 14"T)
- 55-gallon polymer reservoir (34"L x 23"W x 26"T)
- 105-gallon polymer reservoir (69"L x 20"W x 25"T)
- 200-gallon polymer reservoir (151"L x 28"W x 33"T)
- Low Pressure – empty tank light/buzzer indicator
- In-cab variable speed pump control (electric models)

- Adjustable Hydraulic proportioning valve (hydraulic models)
- Systems include tank, pump, cab controller, hoses, fittings, ball valve, filter, wiring, connectors, stainless steel brackets and tie-downs
- Enclosed pump system for corrosion resistance
- 304 stainless steel mounts

Benefits

- Provides more efficient salt distribution with fewer applications required
- Speeds the melting process & works at lower temperatures than salt
- Residual material on the pavement lasts longer
- Easy to use and maintain



LS1 & LS3 (55 gal. poly reservoir)



LS4 & LS5 (105 gal. poly reservoir)



LS4T (tailgate mount 105 gal. poly reservoir)



LS6 (30 gal. poly reservoir)



LS7 & LS8 (30 gal. poly reservoir)



LS9



LS10 (two, 400 gal. poly reservoirs)



LS102H (Hydraulic Enclosure with Proportioning Valve)

PART NO.	DESCRIPTION	FITS
LS1	12 VDC, Cab Control, 55 Gal. Poly Reservoir, V-Box Mount	4 cu. yd. +
LS2	12 VDC, Cab Control, Reservoir Excluded, V-Box Mount	3.5 cu. yd. +
LS3	12 VDC, Cab Control, Two 55 Gal. Poly Reservoirs, V-Box Mount	4 cu. yd. +
LS4	12 VDC, Cab Control, 105 Gal. Poly Reservoir, V-Box Mount	3.5 & 6 cu. yd. +
LS4H	Hydraulic, Cab Control, 105 Gal. Poly Reservoir, V-Box Mount	3.5 & 6 cu. yd. +
LS4T	12 VDC, Tailgate Mount, Cab Control, 105 Gal. Poly Reservoir	24" + tall tailgates
LS4TH	Hydraulic, Tailgate Mount, Cab Control, 105 Gal. Poly Reservoir	24" + tall tailgates
LS5	12 VDC, Cab Control, Two 105 Gal. Poly Reservoirs, V-Box Mount	3.5 & 7 cu. yd. +
LS5H	Hydraulic, Cab Control, Two 105 Gal. Poly Reservoirs, V-Box Mount	3.5 & 7 cu. yd. +
LS6	12 VDC, Cab Control, 30 Gal. Poly Reservoir, V-Box Mount	SHPE1500 & SHPE2000 Series
LS6H	Hydraulic, Cab Control, 30 Gal. Poly Reservoir, V-Box Mount	SHPE1500 & SHPE2000 Series
LS7	12 VDC, Cab Control, 30 Gal. Poly Reservoir, V-Box Mount	1400 Series
LS7H	Hydraulic, Cab Control, 30 Gal. Poly Reservoir, V-Box Mount	1400 Series
LS8	12 VDC, Cab Control, Two 30 Gal. Poly Reservoir, V-Box Mount	1400 Series
LS8H	Hydraulic, Cab Control, Two 30 Gal. Poly Reservoir, V-Box Mount	1400 Series
LS9	12 VDC, Cab Control, 30 Gal. Poly Reservoir, Fram Mount	Truck Frame
LS9H	Hydraulic, Cab Control, 30 Gal. Poly Reservoir, Fram Mount	Truck Frame
LS10	12 VDC, Cab Control, Two 400 Gal. Poly Reservoir, V-Box Mount	12' – 16' Spreaders
LS10H	Hydraulic, Cab Control, Two 400 Gal. Poly Reservoir, V-Box Mount	12' – 16' Spreaders
LS102	Enclosure Assembly, Electric, 3.0 GPM w/ Cab Controller	—
LS102H	Enclosure Assembly, Hydraulic, 4.5 GPM w/ Cab Controller	—



WSE1 - Electric Controller



WSE75 - Hydraulic Controller

6196335 for 6' beds 6198335 for 8' beds

- 2" hitch mounted liquid spray system
- 335 gallon poly reservoir/bladder for 6' (#6196335) or 8' (#6198335) pick-up bed/flat bed with built-in tie points
- 6 gallons per minute diaphragm pump dispenses up to 50 gallons per lane mile.
- 12 VDC, 28 amps max, rear quick connect harness
- In-cab on/off control, standard. Pressure switch activates pump on demand
- Quick Detach PVC spray bar
- Stainless steel pump cover w/ LED license plate light
- Light weight, reinforced polymer reservoir rolls-up for bulkhead storage.
- Optional: 3/8" x50' hose reel with adjustable hand-held spray nozzle for side walks, bus shelters and hard to reach areas.
- Quick and simple, one-person installation with hitch pin.
- Lightweight and better visibility than fixed tank systems



335 gal. poly bladder



adjustable spray nozzle - pressure switch activates pump on demand



PART NO.	DESCRIPTION
6196335	In-Bed Liquid Spray System for 6ft. Beds
6198335	In-Bed Liquid Spray System for 8ft. Beds
6190000	System without Reservoir
6191000	Optional Hose Reel with Adjustable Spray Nozzle



Hydraulic Models

96" wide Dump Bodies

Spread Material: bulk salt, salt & sand mix

Feed Mechanism: 6" Auger with 3/8" flighting

Power Source: hydraulic

- Stainless steel or orange powder-coated carbon steel
- Material spread up to 40'
- Hydraulic power drives auger and spinner
- Standard discharge or left discharge
- 10-gauge trough has 3-point hinged bottom cover for easy access to entire auger assembly and one-person cleanout.
- 6" auger with 3/8" flighting, includes auger screen
- 18" poly spinner
- Sealed, self-aligning 1-1/4" diameter bearing with grease fitting
- Low-speed, high-torque orbital motors.
- Hydraulic safety lockout system.
- Optional powder coated spill shields (924F0106PR)
- Optional stainless steel spill shields (924F0106SSPR)
- See additional specs and individual part number on page 35



UTS auger screen

304SS

92420SSA
(standard discharge)

AVAILABLE
w/STANDARD,
CENTER & LEFT
DISCHARGE,
8in. or 15in.
SIDE SHIELDS

92426SSA
(left discharge)



Electric Models

96" wide Dump Bodies
(for trucks without central hydraulics)

Spread Material: bulk salt, salt & sand mix

Feed Mechanism: 6" Auger with 3/8" flighting

Power Source: electric

- 304 stainless steel
- Material spread up to 25'
- Two 12 VDC direct drive motors (3/4 HP for auger, 1/2 HP for spinner)
- Standard discharge or center discharge
- 14" poly spinner and stainless steel dump body mounting plates
- 10-gauge trough has 3-point hinged bottom cover for easy access to entire auger assembly and one-person cleanout.
- 6" auger with 3/8" flighting, includes auger screen
- Sealed, self-aligning 1-1/4" diameter bearings with grease fittings
- Optional stainless steel spill shields (924F0106SSPR)
- See additional specs and individual part number on page 35

Not recommended for highway use

AVAILABLE with
STANDARD &
CENTER
DISCHARGE



92440SSA
(standard discharge)

304SS



92441SSA
(center discharge)



UTS auger screen



3016934 - Heavy Duty
Variable Speed Controller



9035000

1-Ton/Super-Duty Dump Bodies

Spread Material: bulk salt, salt & sand mix

Feed Mechanism: dual flight auger and breaker bar with mixing tines

Power Source: electric

- 304 stainless steel body
- Material spread up to 25'
- Two 12 VDC direct drive motors (3/4 HP for auger, 1/2 HP for spinner)
- Auger (5" O.D. x 2.4" I.D. x 20"L) with mixing tines
- Hinged 14" poly spinner
- See additional specs and individual part number on page 35

5535000

All DumperDogg® Dump Inserts

Spread Material: bulk salt, salt & sand mix

Feed Mechanism: dual flight auger and breaker bar with mixing tines

Power Source: electric

- 304 stainless steel body
- Material spread up to 25'
- Two 12 VDC direct drive motors (3/4 HP for auger, 1/2 HP for spinner)
- Auger (5" O.D. x 2.4" I.D. x 20"L) with mixing tines
- Hinged 14" poly spinner
- See additional specs and individual part number on page 35



3016934 - Heavy Duty Variable Speed Controller



WB100B & WB200B

Spread Material: ice melt, bagged salt

Feed Mechanism: flowgate

- 1.5 cubic feet poly hopper, 100 lbs
- 3-flap adjustable poly deflector
- Spread range up to 24 ft.
- Fully-welded frame
- 13" pneumatic tires
- Flow regulator with solid control linkage
- Additional fixed rear deflector
- Hopper screen
- Plastic rain cover
- Commercial grade stainless steel gears
- See additional specs and individual part number on page 33



WB100B
carbon steel frame

WB200B
stainless steel frame

WB400

Spread Material: ice melt, bagged salt

Feed Mechanism: agitator

- 44" wide drop spreader is ideal for sidewalks and areas near sensitive foliage.
- 2.5 cu. ft. poly hopper with 200 lb. capacity.
- Stainless steel agitator and trough
- 90% assembled.
- Stainless steel main frame, discharge, auger and shaft assembly.
- Nylon bushings for smooth action.
- Large 13" pneumatic tires.
- Solid control linkage for discharge adjustment, and metal screen to prevent material jamming.
- Plastic rain cover
- See additional specs and individual part number on page 33



WB400

Poly Salt Boxes

- Durable, corrosion free construction
- Double panel, sloped lid with integral hasp
- Hand holds for ease of carrying
- Fork lift slots
- Stackable (9031100)
- 9031100: 36"W x 24"D x 30"H
- 9031105: 36"W x 24"D x 20"H (Ships UPS)
- 9031110: Salt Scoop



Light Bar Kits

- **8891144:** 44" LED Light Bar Kit (Includes (2) Red LED Round STT lights, (2) Amber LED Round Strobe lights, (3) Red LED Round Marker lights, Wire Harness, (2) LED Load Equalizers and Lightbar)
- **8891145:** 44" LED Light Bar Kit (Includes (2) Red LED Oval STT lights, (2) Amber LED Oval Strobe lights, (3) Red LED Round Marker lights, Wire Harness, (2) LED Load Equalizers and Lightbar)
- **8891167:** 66" LED Light Bar Kit (Includes (4) Red LED Round STT lights, (2) Amber LED Round Strobe lights, (3) Red LED Round Marker lights, Wire Harness, (2) LED Load Equalizers and Lightbar)
- **8891168:** 66" LED Light Bar Kit (Includes (2) Red LED Oval STT lights, (2) Clear LED Oval Back-Up lights, (2) Amber LED Oval Strobe lights, (3) Red LED Round Marker lights, Wire Harness, (2) LED Load Equalizers and Lightbar)
- **8891169:** 66" LED Light Bar Kit (Includes (4) Red LED Oval STT lights, (2) Amber LED Oval Strobe lights, (3) Red LED Round Marker lights, Wire Harness, (2) LED Load Equalizers and Lightbar)



8891144 Light Bar Kit



8891145 Lightbar Kit



8891167 Lightbar Kit



8891169 Lightbar Kit

Driveway Markers

- 5/16" x 48"
- Pencil end for easy staking
- Rounded end resists splintering
- 1308600: Orange Markers
- 1308605: Yellow Markers



Light Options For Spreaders

See more at www.buyersproducts.com/Electrical-Lighting



1492100 - 5" 12V-24V Clear, 2.92 Amps, 35 Watts



1492110 - 5" 12V-24V, Clear, 54 LED's, .3 Amps, 375 Lumens



1492111 - 5" 12V-24V, Amber, 54 LED's, .3 Amps, 375 Lumens



1492115 - 5" 12V-24V, Clear, 6 LED's, 1.5 Amps, 1350 Lumens

BRIGHTER LED's



1492116 - 5" 12V-24V, Amber, 6 LED's, 1.5 Amps, 1350 Lumens

Tie Down Kit

- Part No. 3010548
- Heavy-Duty Chain & Turn Buckle Tie Down Kit
- Zinc Plated Hardware
- Powder Coated Brackets

3010548
for 6-16 cu. yd.
Municipal Spreaders

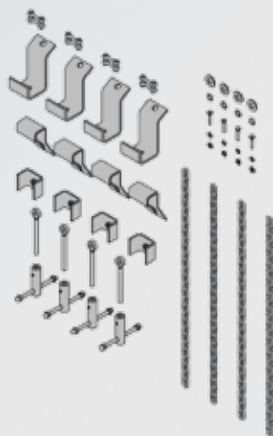

Dump Body Tailgate Lock Kit

- Part No. 3008560
- 3" Structural Steel Channel
- 1.25" Pins
- Black Powder Coat Finish

3008560
for all Municipal
Spreaders

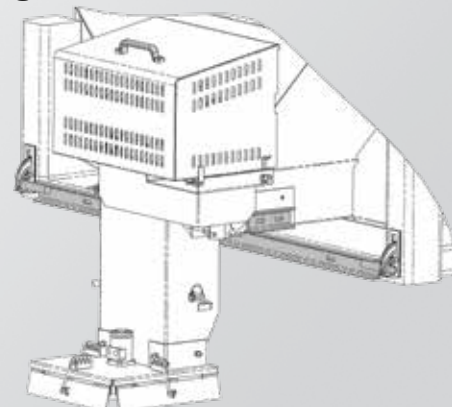

PART NUMBER	CAPACITY	HEIGHT	WIDTH	LENGTH OVERALL	HOPPER LENGTH	FEED MECHANISM
WALK BEHINDS						
PG 31						
WB100B	1.5 cu.ft./100 lb.	31.5"	26.5"	22.5"	19"	Gravity Feed
WB200B	1.5 cu.ft./100 lb.	31.5"	26.5"	22.5"	19"	Gravity Feed
WB400	2.5 cu.ft./200 lb.	35"	44"	18.3"	43.1"	Gravity Feed

PART NUMBER	CAPACITY	HEIGHT	WIDTH	LENGTH OVERALL	HOPPER LENGTH	FEED MECHANISM
ELECTRIC TAILGATE						
PGS 4-9						
TGSUV1B	4.4 cu ft.	40.5"	22.5"	21"	19"	manual open/close gate w/ gravity feed
TGSUVPROA	4.4 cu. ft.	40.5"	22.5"	21"	19"	gravity feed w/vertical 12 VDC auger assist
TGS01B	8 cu. ft.	45.7"	29.7"	26"	26"	gravity feed w/vertical 12 VDC auger assist
TGS02	3.0 cu. ft.	31.5"	30.9"	30"	18.3"	Horizontal Auger Feed
TGS03	8 cu. ft.	45"	38"	38"	28"	Horizontal Auger Feed
TGS03RED	8 cu. ft.	45"	38"	38"	28"	Horizontal Auger Feed
TGS03YEL	8 cu. ft.	45"	38"	38"	28"	Horizontal Auger Feed
TGS05B	10.79 cu ft.	40.1"	54.3"	52.25"	23"	gravity feed w/vertical 12 VDC auger assist
TGS06	10 cu. ft.	40"	63"	52"	26.9"	manual open/close gate w/ gravity feed
TGS07	11 cu. ft.	46"	53"	51"	26"	Horizontal Auger Feed
TGS07RED	11 cu. ft.	46"	53"	51"	26"	Horizontal Auger Feed
TGS07YEL	11 cu. ft.	46"	53"	51"	26"	Horizontal Auger Feed

PART NUMBER	CAPACITY	HEIGHT	WIDTH	LENGTH OVERALL	HOPPER LENGTH	FEED MECHANISM
ELECTRIC DRIVE						
PGS 10-19						
SHPE0750	0.75 cu. yds.	28"	48"	48"	53"	2.5" Stainless Steel Auger & Trough
SHPE0750X	0.75 cu. yds.	28"	48"	48"	53"	2.5" Stainless Steel Auger & Trough
SHPE1000	1.0 cu. yds	34"	48"	48"	68"	2.5" Stainless Steel Auger & Trough
SHPE1000X	1.0 cu. yds	34"	48"	48"	68"	2.5" Stainless Steel Auger & Trough
SHPE1500	1.5 cu. yds.	38"	50.5"	50.5"	87.3"	2.5" Stainless Steel Auger & Trough
SHPE1500X	1.5 cu. yds.	38"	50.5"	50.5"	87.3"	2.5" Stainless Steel Auger & Trough
SHPE1500RED	1.5 cu. yds.	38"	50.5"	50.5"	87.3"	2.5" Stainless Steel Auger & Trough
SHPE1500XRED	1.5 cu. yds.	38"	50.5"	50.5"	87.3"	2.5" Stainless Steel Auger & Trough
SHPE1500YEL	1.5 cu. yds.	38"	50.5"	50.5"	87.3"	2.5" Stainless Steel Auger & Trough
SHPE1500XYEL	1.5 cu. yds.	38"	50.5"	50.5"	87.3"	2.5" Stainless Steel Auger & Trough
SHPE2000	2 cu. yds.	40"	47.8"	47.8"	96"	2.5" Stainless Steel Auger & Trough
SHPE2000X	2 cu. yds.	40"	47.8"	47.8"	96"	2.5" Stainless Steel Auger & Trough
SHPE2000RED	2 cu. yds.	40"	47.8"	47.8"	96"	2.5" Stainless Steel Auger & Trough
SHPE2000XRED	2 cu. yds.	40"	47.8"	47.8"	96"	2.5" Stainless Steel Auger & Trough
SHPE2000YEL	2 cu. yds.	40"	47.8"	47.8"	96"	2.5" Stainless Steel Auger & Trough
SHPE2000XYEL	2 cu. yds.	40"	47.8"	47.8"	96"	2.5" Stainless Steel Auger & Trough
SHPE2250	2.2 cu. yds.	44"	48"	48"	98.5"	5.25" Carbon Steel Variable Pitch Auger, Stainless Trough
SHPE2250RED	2.2 cu. yds.	44"	48"	48"	98.5"	5.25" Carbon Steel Variable Pitch Auger, Stainless Trough
SHPE2250YEL	2.2 cu. yds.	44"	48"	48"	98.5"	5.25" Carbon Steel Variable Pitch Auger, Stainless Trough
1400601SS	2.0 cu. yds.	32.1"	47"	47"	96"	12"W Conveyor Chain
1400701SS	1.5 cu. yds.	32.1"	47"	47"	72"	12"W Conveyor Chain
SHPE3000	3 cu. yds.	52.7"	49.6"	48"	114"	6" Carbon Steel Auger, Stainless Steel Trough
SHPE3000CH	3 cu. yds.	52.7"	49.6"	48"	114"	12"W Conveyor Chain
SHPE4000	4 cu. yds.	43.5"	74"	74"	99.5"	5.5" Carbon Steel Auger, Stainless Steel Trough
SHPE6000	6 cu. yds.	57"	77"	77"	127"	6" Carbon Steel Auger, Stainless Steel Trough

PART NUMBER	CAPACITY	HEIGHT	WIDTH	LENGTH OVERALL	HOPPER LENGTH	FEED MECHANISM
GAS DRIVE						
PG 20						
1400200SS	1.5 cu. yds.	32.1"	47"	47"	72"	12"W Conveyor Chain
1400250SS	1.5 cu. yds.	32.1"	47"	47"	72"	12"W Conveyor Chain
1400050	2 cu. yds.	32.1"	47"	47"	96"	12"W Conveyor Chain
1400100	2 cu. yds.	32.1"	47"	47"	96"	12"W Conveyor Chain
1400050SS	2 cu. yds.	32.1"	47"	47"	96"	12"W Conveyor Chain
1400100SS	2 cu. yds.	32.1"	47"	47"	96"	12"W Conveyor Chain
1400400	2 cu. yds.	35"	47"	47"	95.5"	12"W Conveyor Chain
1400450	2 cu. yds.	35"	47"	47"	95.5"	12"W Conveyor Chain
1400300SS	2.5 cu. yds.	32.1"	47"	47"	120"	12"W Conveyor Chain
1400350SS	2.5 cu. yds.	32.1"	47"	47"	120"	12"W Conveyor Chain

PART NUMBER	CAPACITY	HEIGHT	WIDTH	LENGTH OVERALL	HOPPER LENGTH	FEED MECHANISM
3.5 – 5 CU. YD. CONVEYOR MUNICIPAL						
PG 22						
1400475SS	3.5 cu. yds.	45.5"	70"	115.9"	96"	14.5"W Conveyor Chain, Gas
1400475SSE	3.5 cu. yds.	45.5"	70"	115.9"	96"	14.5"W Conveyor Chain, Electric
1400475SSH	3.5 cu. yds.	45.5"	70"	118.8"	96"	14.5"W Conveyor Chain, Hydraulic
1400500SS	4.0 cu. yds.	45.5"	70"	127.9"	108"	14.5"W Conveyor Chain, Gas
1400500SSE	4.0 cu. yds.	45.5"	70"	127.9"	108"	14.5"W Conveyor Chain, Electric
1400500SSH	4.0 cu. yds.	45.5"	70"	130.0"	108"	14.5"W Conveyor Chain, Hydraulic
1400550SS	4.5 cu. yds.	45.5"	70"	138.9"	120"	14.5"W Conveyor Chain, Gas
1400550SSE	5.0 cu. yds.	45.5"	70"	138.9"	120"	14.5"W Conveyor Chain, Electric
1400550SSH	4.5 cu. yds.	45.5"	70"	141.8"	120"	14.5"W Conveyor Chain, Hydraulic
1400560SS	5.0 cu. yds.	50.6"	70"	138.9"	120"	14.5"W Conveyor Chain, Gas
1400560SSE	5.0 cu. yds.	50.6"	70"	138.9"	120"	14.5"W Conveyor Chain, Electric
1400560SSH	5.0 cu. yds.	50.6"	70"	141.8"	120"	14.5"W Conveyor Chain, Hydraulic

PART NUMBER	CAPACITY	HEIGHT	WIDTH	LENGTH OVERALL	HOPPER LENGTH	FEED MECHANISM
2.5 – 3.0 CU. YD. CONVEYOR MID-SIZE						
PG 21						
1400455SS	2.5 cu. yds.	38.0"	38.0"	115.9"	96"	14.5"W Conveyor Chain, Gas
1400455SSE	2.5 cu. yds.	38.0"	38.0"	116.5"	96"	14.5"W Conveyor Chain, Electric
1400455SSH	2.5 cu. yds.	38.0"	38.0"	118.8"	96"	14.5"W Conveyor Chain, Hydraulic
1400460SS	2.75 cu. yds.	38.0"	38.0"	127.9"	108"	14.5"W Conveyor Chain, Gas
1400460SSE	2.75 cu. yds.	38.0"	38.0"	128.5"	108"	14.5"W Conveyor Chain, Electric
1400460SSH	2.75 cu. yds.	38.0"	38.0"	130.0"	108"	14.5"W Conveyor Chain, Hydraulic
1400465SS	3.0 cu. yds.	38.0"	38.0"	138.9"	120"	14.5"W Conveyor Chain, Gas
1400465SSE	3.0 cu. yds.	38.0"	38.0"	140.5"	120"	14.5"W Conveyor Chain, Electric
1400465SSH	3.0 cu. yds.	38.0"	38.0"	141.8"	120"	14.5"W Conveyor Chain, Hydraulic

PART NUMBER	CAPACITY	HEIGHT	WIDTH	LENGTH OVERALL	HOPPER LENGTH	FEED MECHANISM
HYDRAULIC 7 - 10 CU. YD. AUGER MUNICIPAL						
PG 23						
1471056SSH	7 cu. yds.	55.25"	87.7"	84"	120"	7" Hard Surface, Multi Pitch Auger
1471156SSH	8 cu. yds.	55.25"	87.7"	84"	132"	7" Hard Surface, Multi Pitch Auger
1471256SSH	9 cu. yds.	55.25"	87.7"	84"	144"	7" Hard Surface, Multi Pitch Auger
1471456SSH	10 cu. Yds	55.25"	87.7"	84"	168"	7" Hard Surface, Multi Pitch Auger

PART NUMBER	CAPACITY	HEIGHT	WIDTH	LENGTH OVERALL	HOPPER LENGTH	FEED MECHANISM
HYDRAULIC 6 - 16 CU. YD. CONVEYOR MUNICIPAL						
PGS 24-25						
1450657SSH	6 cu. yd.	57"	82"	82"	108"	24"W Conveyor, 50:1 Gearbox ratio
1425657SSH	6 cu. yd.	57"	82"	82"	108"	24"W Conveyor, 25:1 Gearbox ratio
1406657SSH	6 cu. yd.	57"	82"	82"	108"	24"W Conveyor, 6:1 Gearbox ratio
1450757SSH	7 cu. yd.	57"	82"	82"	120"	24"W Conveyor, 50:1 Gearbox ratio
1425757SSH	7 cu. yd.	57"	82"	82"	120"	24"W Conveyor, 25:1 Gearbox ratio
1406757SSH	7 cu. yd.	57"	82"	82"	120"	24"W Conveyor, 6:1 Gearbox ratio
1450863SSH	8 cu. yd.	63"	82"	82"	120"	24"W Conveyor, 50:1 Gearbox ratio
1425863SSH	8 cu. yd.	63"	82"	82"	120"	24"W Conveyor, 25:1 Gearbox ratio
1406863SSH	8 cu. yd.	63"	82"	82"	120"	24"W Conveyor, 6:1 Gearbox ratio
1450969SSH	9 cu. yd.	69"	82"	82"	120"	24"W Conveyor, 50:1 Gearbox ratio
1425969SSH	9 cu. yd.	69"	82"	82"	120"	24"W Conveyor, 25:1 Gearbox ratio
1406969SSH	9 cu. yd.	69"	82"	82"	120"	24"W Conveyor, 6:1 Gearbox ratio
1451057SSH	10 cu. yds.	57"	82"	82"	144"	24"W Conveyor, 50:1 Gearbox ratio
1421057SSH	10 cu. yds.	57"	82"	82"	144"	24"W Conveyor, 25:1 Gearbox ratio
1461057SSH	10 cu. yds.	57"	82"	82"	144"	24"W Conveyor, 6:1 Gearbox ratio
1451163SSH	11 cu. yds.	63"	82"	82"	144"	24"W Conveyor, 50:1 Gearbox ratio
1421163SSH	11 cu. yds.	63"	82"	82"	144"	24"W Conveyor, 25:1 Gearbox ratio
1461163SSH	11 cu. yds.	63"	82"	82"	144"	24"W Conveyor, 6:1 Gearbox ratio
1451369SSH	13 cu. yds.	69"	82"	82"	144"	24"W Conveyor, 50:1 Gearbox ratio
1421369SSH	13 cu. yds.	69"	82"	82"	144"	24"W Conveyor, 25:1 Gearbox ratio
1461369SSH	13 cu. yds.	69"	82"	82"	144"	24"W Conveyor, 6:1 Gearbox ratio
1451257SSH	12 cu. yds.	57"	82"	82"	168"	24"W Conveyor, 50:1 Gearbox ratio
1421257SSH	12 cu. yds.	57"	82"	82"	168"	24"W Conveyor, 25:1 Gearbox ratio
1461257SSH	12 cu. yds.	57"	82"	82"	168"	24"W Conveyor, 6:1 Gearbox ratio
1451363SSH	13 cu. yds.	63"	82"	82"	168"	24"W Conveyor, 50:1 Gearbox ratio
1421363SSH	13 cu. yds.	63"	82"	82"	168"	24"W Conveyor, 25:1 Gearbox ratio
1461363SSH	13 cu. yds.	63"	82"	82"	168"	24"W Conveyor, 6:1 Gearbox ratio
1451469SSH	14 cu. yds	69"	82"	82"	168"	24"W Conveyor, 50:1 Gearbox ratio
1421469SSH	14 cu. yds	69"	82"	82"	168"	24"W Conveyor, 25:1 Gearbox ratio
1461469SSH	14 cu. yds	69"	82"	82"	168"	24"W Conveyor, 6:1 Gearbox ratio

PART NUMBER	CAPACITY	HEIGHT	WIDTH	LENGTH OVERALL	HOPPER LENGTH	FEED MECHANISM
UNDER TAILGATE						
PGS 28-29						
92440SSA	N/A	31.25"/34.25"	96"	25"	N/A	6" Auger w/3/8" fighting, Electric
92441SSA	N/A	31.25"/34.25"	96"	25"	N/A	6" Auger w/ 3/8" fighting, Electric
92420A	N/A	31.25"/34.25"	96"	18"	N/A	6" Auger w/3/8" fighting, Hydraulic
92420SSA	N/A	31.25"/34.25"	96"	18"	N/A	6" Auger w/3/8" fighting, Hydraulic
92421SSA	N/A	38.00"/41.00"	96"	19"	N/A	6" Auger w/3/8" fighting, Hydraulic
92425SSA	N/A	31.25"/34.25"	96"	18"	N/A	6" Auger w/3/8" fighting, Hydraulic
92428SSA	N/A	31.25"/34.25"	96"	18"	N/A	6" Auger w/3/8" fighting, Hydraulic
92426SSA	N/A	38.00"/41.00"	96"	19"	N/A	6" Auger w/3/8" fighting, Hydraulic
92430A	N/A	31.25"/34.25"	96"	18"	N/A	6" Auger, 3/8" fighting, 5:1 Gearbox ratio, Hydraulic
92430SSA	N/A	31.25"/34.25"	96"	18"	N/A	6" Auger, 3/8" fighting, 5:1 Gearbox ratio, Hydraulic

PART NUMBER	CAPACITY	HEIGHT	WIDTH	LENGTH OVERALL	HOPPER LENGTH	FEED MECHANISM
ELECTRIC REPLACEMENT TAILGATE						
PG 30						
9035000	N/A	36"	73" - 95"	N/A	N/A	Dual Flight Augers w/Mixing Tines
5535000	N/A	36"	73" - 95"	N/A	N/A	Dual Flight Augers w/Mixing Tines

DESIGN BUILD DISTRIBUTE SUPPORT



Buyers Products Company 9049 Tyler Blvd. Mentor, OH 44060
440.974.8888 Toll-Free Fax 800.841.8003 www.buyersproducts.com

LITSPREADERS Rev C